

IV.1.Introduction

A control system consists of two Subsystems a plant and a controller the plant is an entity controlled by the controller , in our work the plant is concentration of blood glucose are discussed.

Diabetic patient model discussed in Sections1 and 2.was implemented in Simulink along with Matlab7.9.

This chapter explains the simulation of the PID controller using System Generator and Matlab /Simulink.

And we discuss about a direct comparison between the results obtained with the PID tuning controller and the PID based PSO algorithm controller are shown, In particular, figures and tables of the Regulation of blood Glucose level in Diabetes controllers with the selected settings are reported along with the robustness test And implanted the optimal values of PID controller in Xilinx System Generator for downloading the HDL coder to implement in the hardware (FPGA).

IV.2.Controller Design

The controller design consists of two main steps: (i) find a continuous low-order approximation of the transfer function model in **Eq.III.8** and (ii) use this approximation to implement a PID controller using the PSO algorithm design method. In the following two sections, these two steps are described.

IV.2.1 .Simulator PID Implementation

The two main parts of the controller part of the simulator are a setup script and a run-time algorithm. The setup script allows the controller to be tuned for each subject and thus provides the personalized information to the run-time controller. The run-time algorithm applies the tuned control algorithm.

The control algorithm is implemented in the form of a Simulink block where the input and the output of the control block are fixed.

Figure IV.1 shows the closed loop control system of the our model, the yellow block is the controller and orange block is our process.

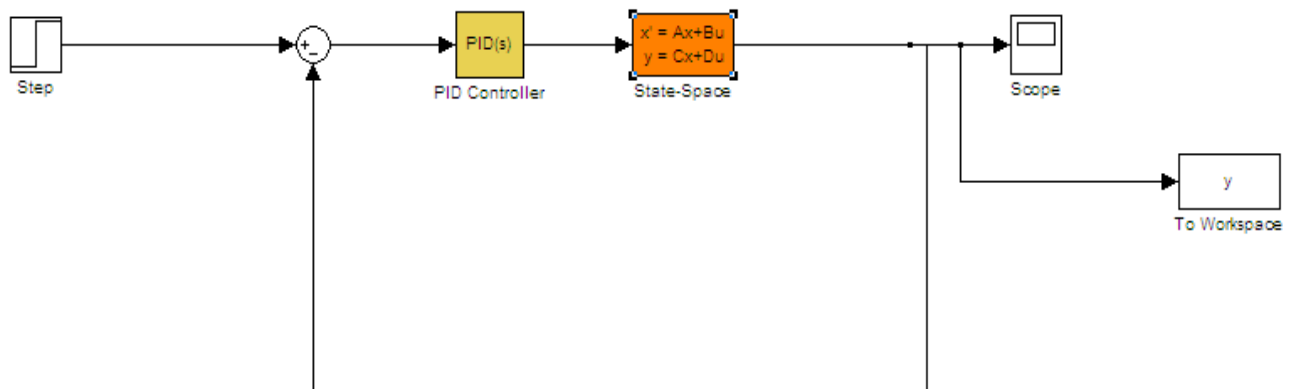

FigureIV.1: Regulation Blood Glucose closed-loop control system.

The simulation results adapted to these blocks are shown in **FigureIV.2**.

The performances of the proposed classical PID controller for our model are given in **TableIV.1**.

TableIV.1.: Performances of the PID controller

Parameter	Value	Parameter of the system response	Value
K_p	0.42	Rise time (sec)	17.4
K_i	0.0015	Setting time(sec)	521
K_d	30.96	Overshoot (%)	8.77
		Peak	1.09

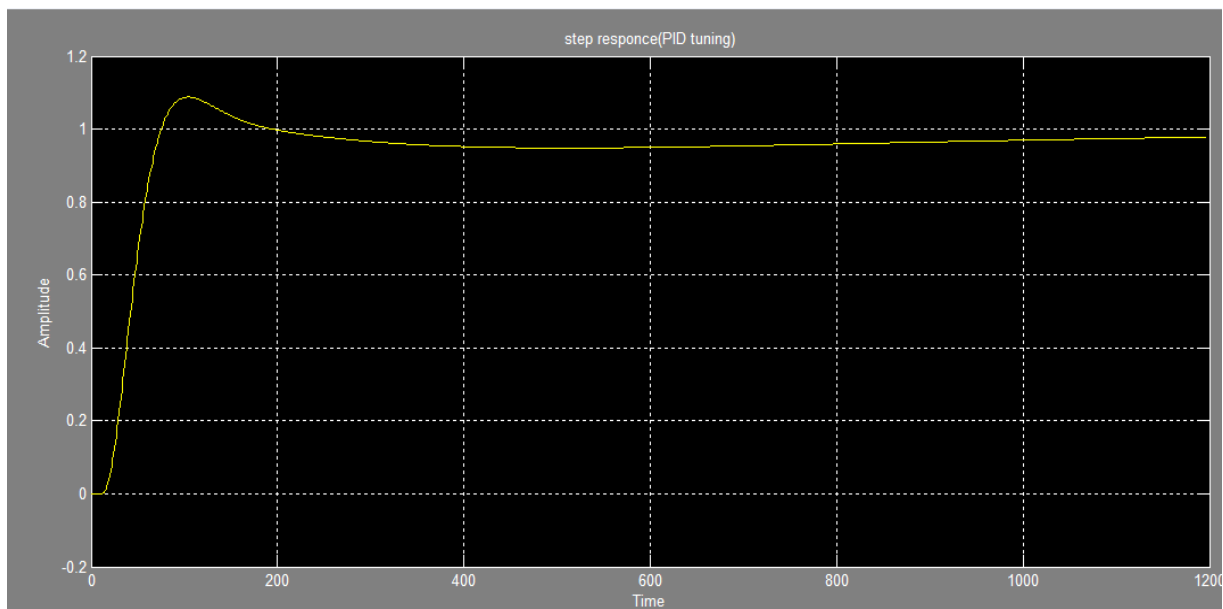

Figure IV.2:The step response of PID

IV.2.3. Results Of The Implemented PSO PID Controller

In this work a PSO is used to find the optimal parameters of Regulation of blood Glucose Diabetes PID control system. **FigureIV.3.** shows the block diagram of optimal PID-PSO control for the our system. . In the proposed PSO method each particle contains three members P, I and D . It means that the search space has three dimension and particles must ‘fly’ in a three dimensional space.

The results of the implemented particle swarm optimization PID Controller will be analyzed. The PSO designed PID controller is initially initialized with number of iteration $n=22$ and the response analyzed. The response of the PSO designed PID will then be analyzed for the smallest overshoot, fastest rise time and the fastest settling time. The best response will then be selected.

The optimum parameter values that achieved better solution are listed in **Table IV.2**.

From the following responses, the PSO designed PID will be compared to the Tuning PID controller.

In order to demonstrate the performance of the PSO. The numerical values of the Regulation Glucose models parameters are listed in **Table IV.2**.

Table IV.2: The parameters of PID-PSO

The parameters(PID)	Values	Parameters of response	Values
K_p	0.21	Rise time (sec)	18.7
K_i	0.0031	Setting time(sec)	57.5
K_d	28.4	Overshoot (%)	6.6
		Peak	1.06

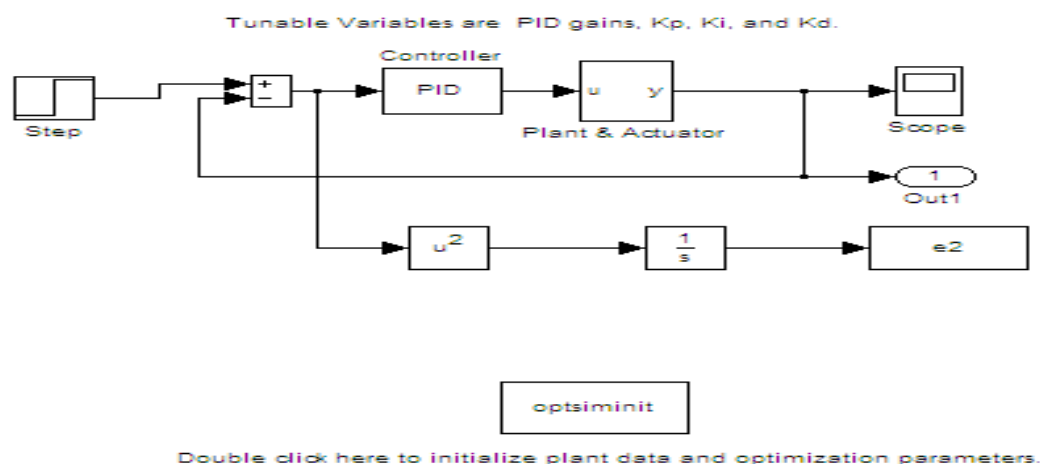

Figure.IV.3 : the Block Diagram of optimal PID –PSO

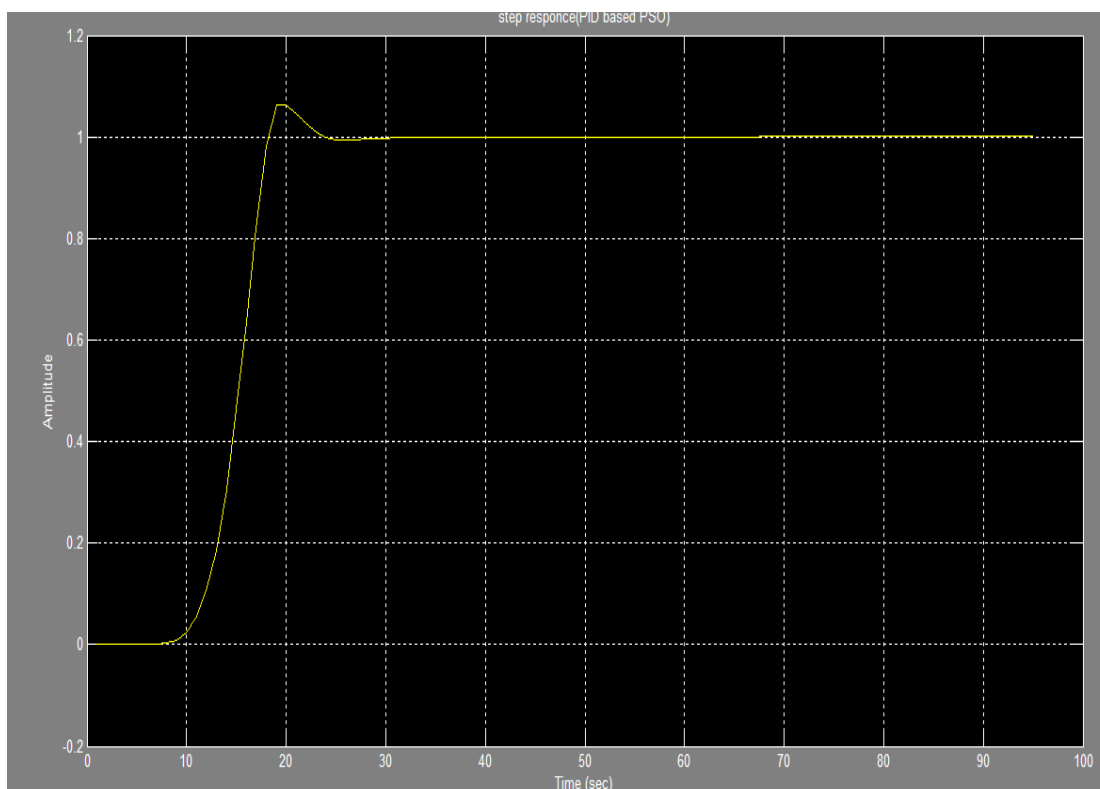

Figure.IV.4 : The step response of optimal PID –PSO

IV.2.4 .Results And Simulation Digital PID in the System Generator

The System Generator is a collection of Simulink block sets that permit interaction between Hardware and modeled.

The FPGA results of the closed loop system are obtained using the simulator of the Xilinx software package . At the same time, the closed loop system was simulated using MATLAB, SIMULINK program (Ver9). Where (the difference between the MATLAB results and FPGA software results is that the first depend on the software calculation according to the theory algorithms, while the other depend on the practical implementation of a digital circuit).

the best values of controller constants were: K_p is 1.6, K_i is 0.2 and K_d is 28.4 The proposed based PID controller is implemented using the Xilinx Inc FPGA technology and can be used as a general purpose controller for different applications.

The simulation results obtained with the generated VHDL.

TableIV.3. shows the minimum number of multiplications, additions and registers required for the PID controller without conversions block.

TableIV.3: The minimum number of multiplications, additions and registers

Multeplexers	07
Addition	05
Substraction	01
Registers	02

TableIV.3: Arithmetic Number for PID controller

The simulation results adapted to this block is shown in **Figure IV.5** and **FigurIV.6**

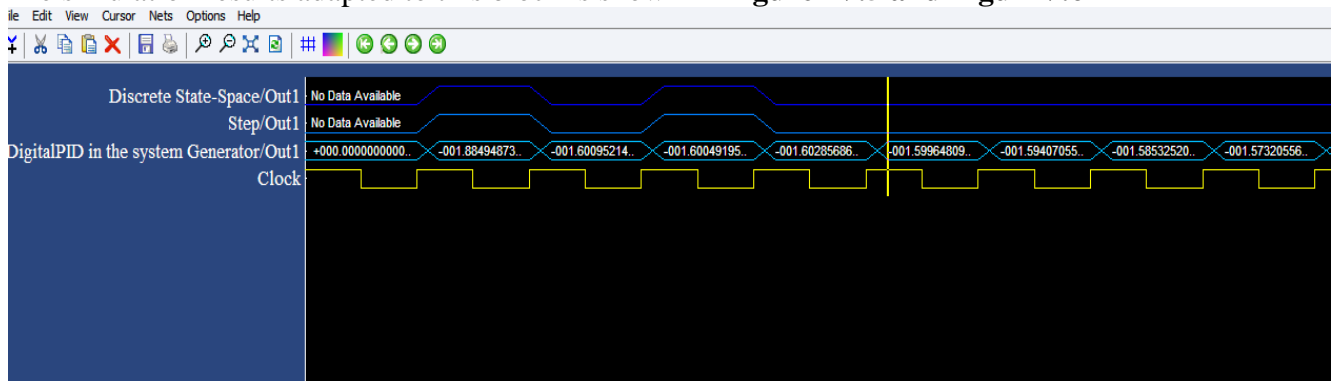

Figure IV.5: out Digital PID in the System Generator

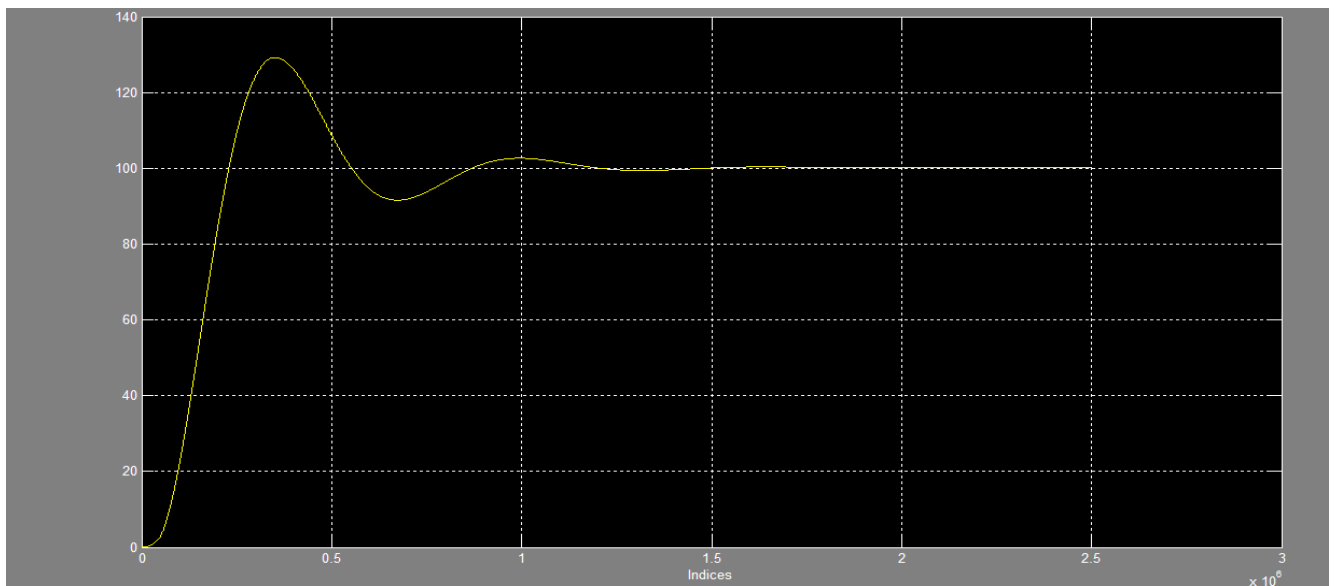

Figure IV.6: The step response of Digital PID in the system Generator.

From the simulation program, we can translate it using System Generator to VHDL and used directly in the FPGA. Likewise, we also recovered from the program in a VHDL simulation program. It is also

possible to use the simulation program written in M-file, by Black Box block. System Generator for DSP is a fully-featured tool for simulation programs for the FPGA.

IV.3.Discussion

We use the two control methods mentioned above to control the blood glucose of type 1 patient , **Figure IV.2.** Shows step Response of our system with PID Controller ,it can shows clearly that the simulation can be accept.

FigureIV.4 shows the step Response of Blood Glucose concentration controlled by the (PSO-PID) controller , the results is more ideal than the classical PID controller .and more effective .

To validate the implantation of the Digital PID controller with (HDL coder) simulation we find this Result in **FigureIV.5.** but not ideal because it can be difficult to guarantee the Result of the hardware implemented the Design faithfully .

IV.4.Conclusion

In this chapter described the difference methods to find optimal(PID) parameters to control the blood glucose of type1 patient .

Compare with the PID controller ,the PSO-PID controller is very effective and it gives more ideal results than the classical PID it can control the glucose concentration more perfect ,But when we designed this controller in Hardware the results is not ideal thane the software.

System Generator eliminates the concern by automatically generating a faithful Hardware implementation.

